

4

3

2

1

REVISION HISTORY					
ECO	ZONE	REV	DESCRIPTION	DATE	APPROVED
		A.01			

B

B

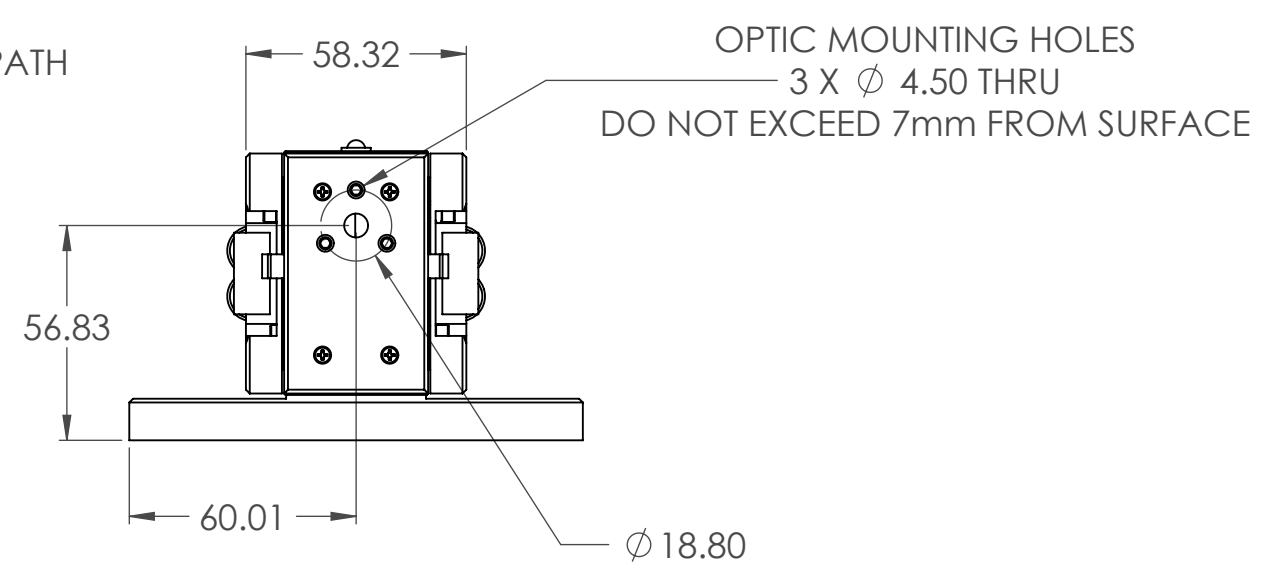
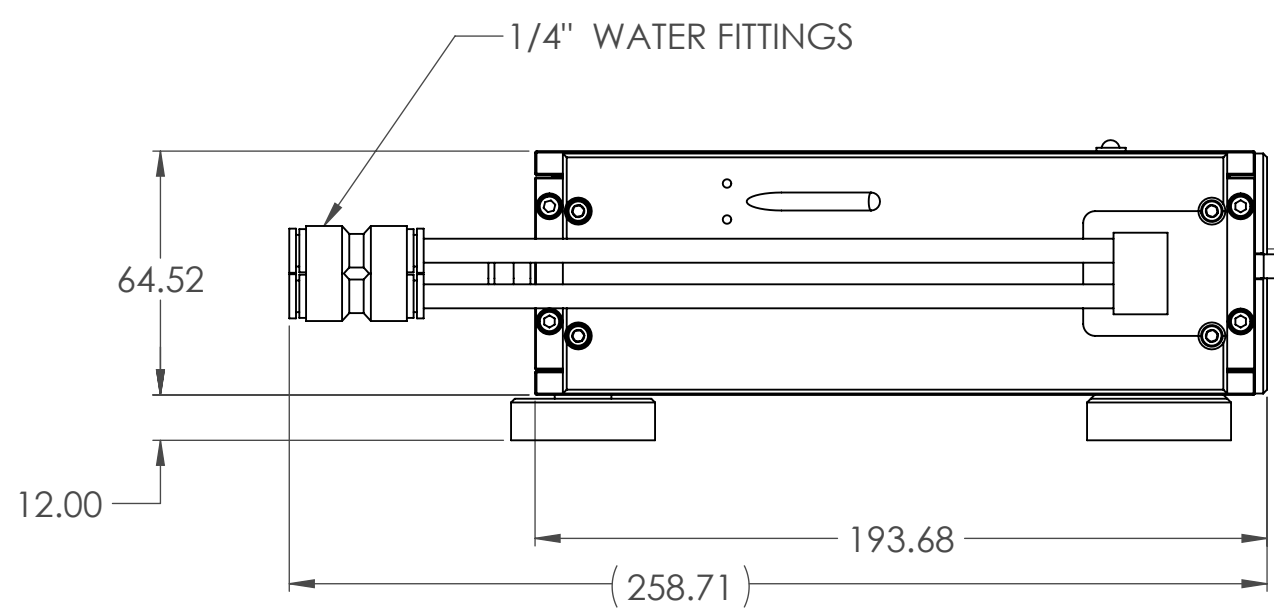

A

A

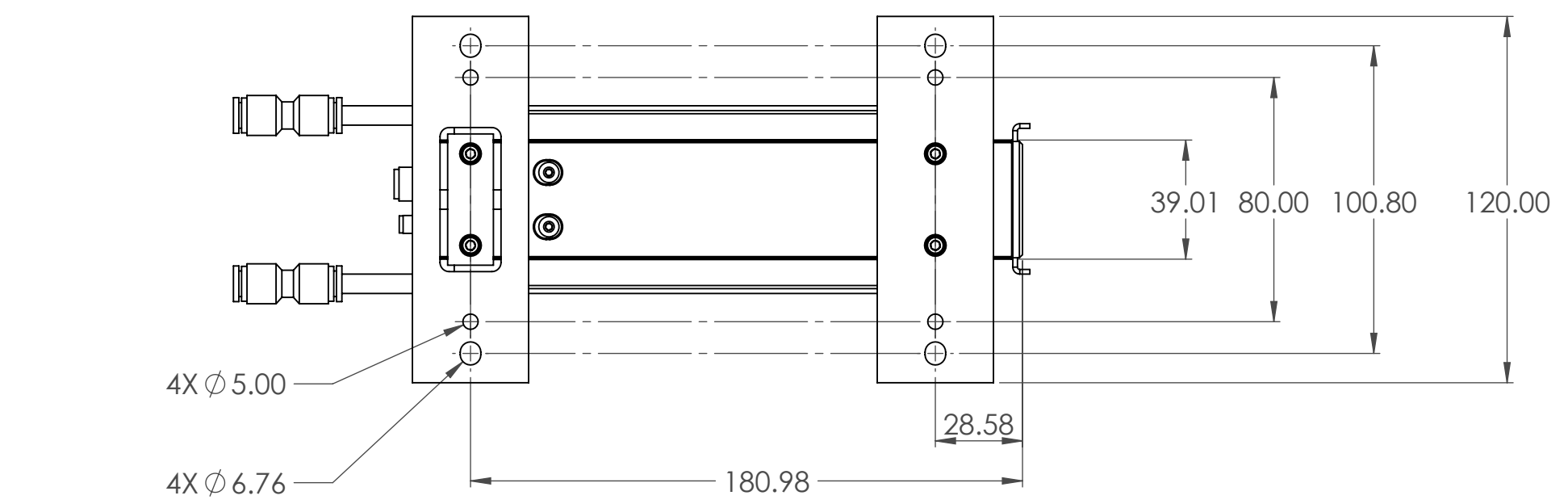

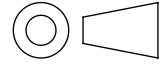
Phone: 425-582-8674 Fax: 425-582-8679 www.accesslaser.com/ purchasing@accesslaser.com	TOLERANCE / UNIT ISO 2768 METRIC 0.5 UP TO 6 : ±0.1 < 6 UP TO 30 : ±0.2 < 30 UP TO 120 : ±0.3 < 120 UP TO 400 : ±0.5 < 400 UP TO 1000 : ±0.8 ANGULAR: MACH ±0°20'		ASME Y14.5-2009 INCHES .x ± .1 .xx ± .01 .xxx ± .005 FRACTIONAL ±1/64 BEND: ± .3 ANGULAR: MACH ± 0°5'		DRAWN BY CHECKED BY APPROVED BY FINISH MATERIAL	THIRD ANGLE PROJECTION  SURFACE FINISH	PART NO. DESCRIPTION: L3-LS-Class_IIIb-WCCL	REV
	PROPRIETARY AND CONFIDENTIAL THE INFORMATION CONTAINED IN THIS DRAWING IS THE SOLE PROPERTY OF ACCESS LASER COMPANY. ANY REPRODUCTION IN PART OR AS A WHOLE WITHOUT THE WRITTEN PERMISSION OF ACCESS LASER COMPANY IS PROHIBITED.			DRAWING SHALL BE IN ACCORDANCE WITH ASME Y14.5-2009		DO NOT SCALE DRAWING	SCALE 1/2	SHEET 1 OF 1

4

3

2

1